

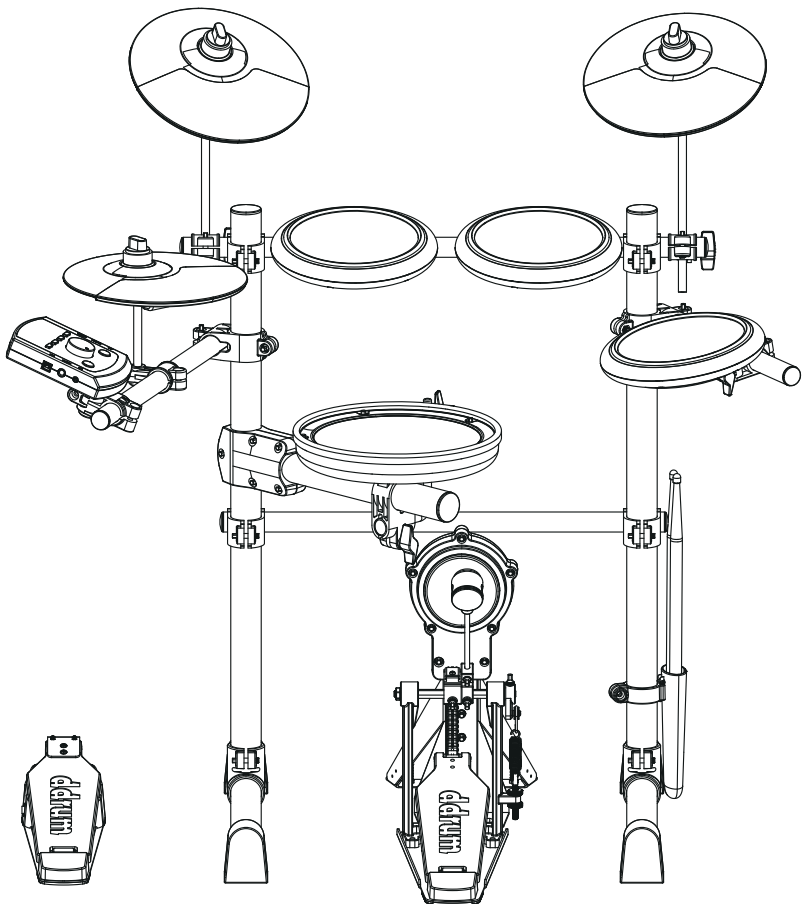

DD EFLEX BT8

Electronic Drum Set



USER MANUAL



MADE IN CHINA



CONTENS

Product Features	4
ddrum EFLEX BT8 Configuration.....	4
Updated Mesh Drum Heads.....	4
Easy to use Module.....	4
Metronome.....	4
Drum Introduction	5
Crash Cymbal.....	5
Ride Cymbal.....	5
Hi-Hat.....	5
Tom Drum.....	5
Snare Drum.....	5
Bass Drum.....	5
Hi-Hat Pedal.....	5
Basic Play Method	6
Playing the Hi-Hat and Hi-Hat Pedal.....	6
Playing the Crash Cymbal.....	6
Playing the Ride Cymbal.....	6
Playing the Bass Drum.....	6
Playing the Snare Drum.....	6
module Introduction	7
How To Use	8
1. Power and Audio Cable Connection.....	8
2. Turn On/Off module.....	8
3. Turn On Drum Amp(if using a drum amp).....	8
4. Select Drum Kit.....	8
5. Song select.....	8
6. Kit Edit.....	9
7. System Setting.....	10
8. Restore Kit Setting.....	11
9. Auto Power Off.....	11
10. Factory Reset.....	12
11. Anti-crosstalk Function.....	12
Menu list	14
Metronome Function	15
Pedals Adjustment	16
Bluetooth	16
USB MIDI	17
Specifications	18
Troubleshooting	19



Thank you for purchasing the ddrum EFLEX BT8 Electronic Drum Set. Please refer to the Assembly Instructions to setup the ddrum EFLEX BT8 Electronic Drum Set. Before you start playing, please read through this manual.

Product Features

ddrum EFLEX BT8 Configuration

The ddrum EFLEX BT8 electronic drumset comes complete with 3 tom pads, snare pad, 3 cymbal pads, hi-hat & bass drum controller, throne and drum sticks.

Updated Mesh Drum Heads

All of the pads including the snare drum use mesh heads, which feel better and are more quiet than standard rubber pads.

Easy to use Module

The ddrum EFLEX BT8 module is designed to be easy to use. It has one volume knob, two drum sound switch buttons, and one metronome button.

Metronome

The ddrum EFLEX BT8 includes a built in metronome. Range is 40-240 BPM.

Drums Introduction

Crash Cymbal

Reference: CR. 9" diameter. The crash cymbal should be positioned at the left side of the drum rack. The crash cymbal includes choke function.

Ride Cymbal

Reference: RD. 9" diameter. The ridecymbal should be positioned at the right side of the drum rack. The ride cymbal includes choke function and has separate bell zone.

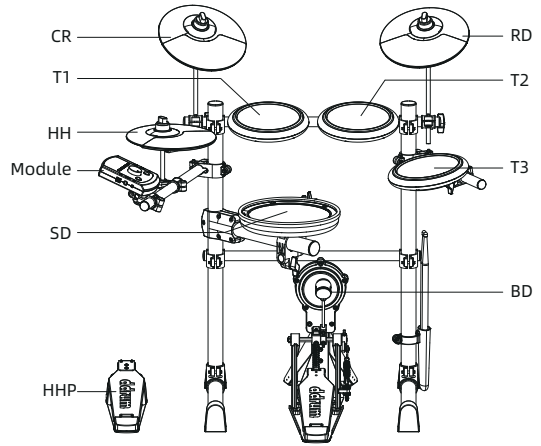

Diagram 1

Hi-Hat

Reference: HH. 9" diameter. The Hi-hat pads to be positioned on the left side of the rack on lower rack arm. (See Diagram 1)

Toms

Reference: T1, T2, T3. 6" diameter mesh tom pads. The tom pads mount to the center and right side rack arms. The mesh heads provide great feeling and quiet sound.

Snare Drum

Reference: SD. 6" diameter dual mesh snare pad. The snare pad should be mounted to the thirorack arm down on the left side and positioned towards the center like a snare drum. The snare pad includes a dual zone function for side sticking sound option.

Bass Drum

Reference: BD 4" diameter. Includes impact pad and complete single pedal.

Hi-Hat Pedal

Reference: HHP. The hi-hat controller is similar to the bass drum controller. Similar to areal hi-hat stand, simply press the controller to make open and closed hi-hat sounds.

Reminder: The reference abbreviation is marked on each pad and the end of each cable for easy setup.

Playing the ddrum EFLEX BT8

This is a brief overview of how to utilize some of the features on the ddrum E-Flex kit.

Hi-hat and hi-hat pedal

Press down on the hi-hat pedal to engage the hi-hat sound. (Please see Diagram 2.) For amore loose sound, release the pedal and strike the hi hat pad. For a closed Hi-Hat soundpress and hold down the hi-hat pedal while striking the hi-hat pad. (Please see Diagram 3.

Bass drum pedal

The bass drum pedal is similar to the hi-hat pedal. Press down on the pedal to engage the bassdrum sound. The ddrum E-Flex has the option for double bass. Simply hold the up and downarrow buttons until the screen shows "BHH". The hi-hat pedal now functions as second bass drum.

Ride cymbal

The Ride cymbal offers two playing zones and choke function. The bow or body of the cymbal canbe played near the edge of the pad. (Please see Diagram 4.) The bell or second zone can beplayed by striking the pad near the bell. (Please see Diagram 5.) To use the choke function, grabthe pad by the highlighted area shown on Diagram 6.

Snare drum

All the pads including the snare drum are velocity sensitive. This means the pad reacts to hardand soft strikes just like a real drum. Soft strikes will be low and hard strikes being loud. (Pleasesee Diagram 7.) The snare drum includes a dual zone function which allows two separatesounds from the drum head and rim. (Please see Diagram 8.)



Diagram 2



Diagram 3



Diagram 4

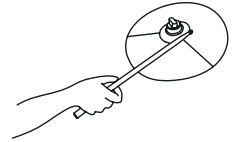

Diagram 5



Diagram 6

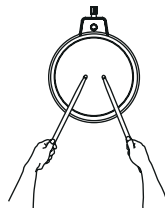
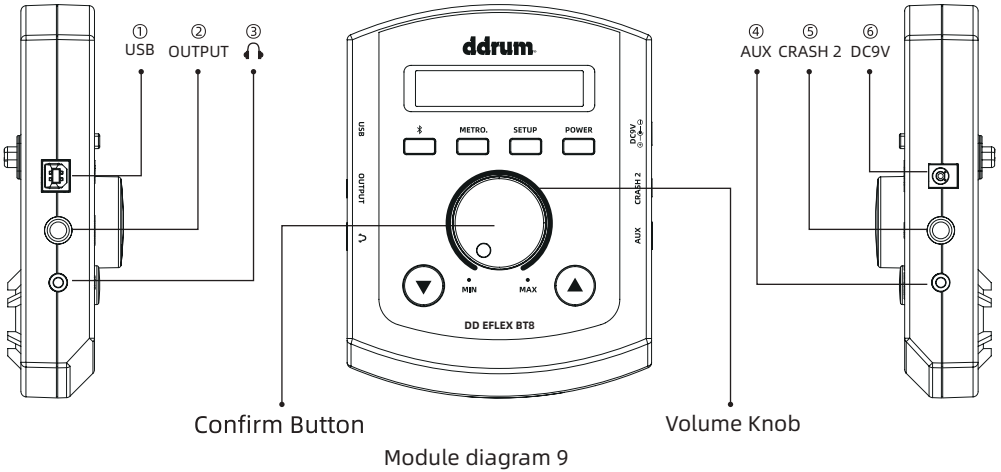

Diagram 7



Diagram 8

Module Introduction



Controls

POWER	Press to turn On / Press and hold to turn Off. (Refer to next page for setting 'AUTO OFF' in '30 MIN' '1 HOUR' , or 'OFF')
▲ ▼	Change sound kits. (Under different modes, the Button controls different functions, refer to function description on next page)
Confirm Button	Confirm each function chose.
METRO.	Press to metronome On/ Off. Press and hold to enter songs select.
SETUP	Enter setup functions and return(Remind: All settings will be saved automatically once they are modified.)
Volume Knob	Control the master volume of the drum kit.
Bluetooth symbol	Bluetooth on/off

Connections

①	USB	USB MIDI socket
②	OUTPUT	6.35mm output
③	Headphone symbol	3.5mm stereo headphone socket
④	AUX	3.5mm AUX IN
⑤	CRASH 2	Crash 2 expand socket
⑥	DC9V	Power socket ⊕ — ⊖



How To

1. Power And Audio Cable Connection

Use the attached audio cable to connect OUTPUT of module to your drum amp or connect your headphone to the earphone port of module. And then connect the power adapter to DC9V port of module.

2. Turn On/Off Module

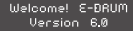
Press POWER button to turn On the machine. Press and hold the POWER button to turn Off the machine. The screen shows below.

Power On:  (Supplied software is subject to change without prior notice.)
Power Off: 

3. Turn On Drum Amp(in using a drum amp)

Turn on the drum amp and adjust the drum amp volume level. Hit the drum pad in the same time and adjust module volume control and the drum amp volume control to make a balance.

4. Select Drum Kit

The default drum kit is Pop Stage. Press "▲" "▼" to select other drum kits, refer to Diagram 10.

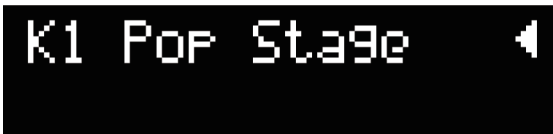

Diagram 10

All drum kits list:

K1 Pop Stage	K6 Metal Live	K11 Fast Funk	K16 Latin Jazz
K2 Pop Studio	K7 Power Metal	K12 Funky Rnb	K17 Electronic
K3 Hard Rock	K8 Metal Studio	K13 J-Standards	K18 Cavort
K4 Old Rock	K9 70's Fusion	K14 Cool Jazz	K19 Techno
K5 Heavy Metal	K10 Modern	K15 Swing Jazz	K20 Dubstep

5. Song Select

After power On, press and hold "METRO." Button, the screen shows press "▲" "▼" button to select song, press confirm button and the selected song starts to play.

Practice songs select and buttons control

Turn power on		→	Press and hold "METRO." button		→	Press "METRO." button to exit song selection.	
Press and hold "METRO." button	Press ▲ ▼ to select song	S1 cool soul	S16 polka	Press confirm button play song	Press "▲" "▼" button to adjust BPM	Other adjustment press SETUP button	Song ACC. volume
		S2 techno	S17 fast funk				Song BASS volume
		S3 dixie	S18 pop swing		Press confirm button to stop song		Song drum volume
S4 waltz	S19 funk shuffle						
S5 easy rock	S20 pop disco						
S6 rock beat	S21 pop ballade						
S7 ballade beat	S22 pop waltz						
S8 salsa	S23 r&b ballade						
S9 break beat	S24 real soul						
S10 shuffle	S25 reggae						
S11 hard rock	S26 easy soul						
S12 slow pop	S27 pop rock						
S13 hip hop	S28 folk						
S14 soul	S29 pop						
S15 mambo	S30 funk						

6. Kit Edit

Step 1: Press "SETUP" to enter kit edit menu. Press "▲" "▼" to select desired parameter to edit including: Pitch, Level, Pan, Rev(Reverb), Velo(Velocity), Sens(sensitivity), Mask (Scan mask time), Note(MIDI note number), Voice. Then press confirm button to enter the parameter.



Diagram11

Reminder:

1. The "SETUP" button edits only the current selected drum kit.
2. The following parameters are shared by all drum kits and take effect for all drum kits: Pan, Velo(Velocity), Sens(sensitivity), Mask (Scan Mask Time), Note(MIDI note number).

Menu of all parameters are as below.

SET[EDIT]-Pitch KICK :63 Pitch: 0~127	SET[EDIT]-Level KICK :125 Level: 0~127	SET[EDIT]-Pan KICK :64 Pan:0~127
SET[EDIT]-Rev. KICK :64 Rev:0~127	SET[EDIT]-Velo. KICK :6 Velo:0~7	SET[EDIT]-Sens. KICK :5 Rev:0~127
SET[EDIT]-Mask KICK :30 Mask: 0~250	SET[EDIT]-Note KICK : Note:21~108	SET[EDIT]-Voice KICK :[BD]5 Voice: 1~20(KICK)

Step 2: After selecting the parameter, strike the desired pad or cymbal. The screen automatically shows the part name which you strike. All the corresponding names are as below.

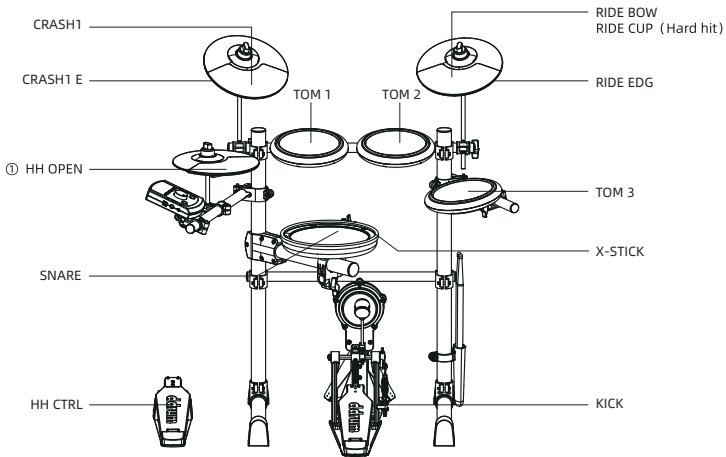

Pad and Cymbal shot names diagram 12

Reminder: 1. Stamp on hi-hat pedal and strike hi-hat cymbal, the screen shows HH CLOSE (hi-hat close).

Step 3: Press "▲" "▼" to select desired parameter, refer to Diagram 13. Press confirm button to confirm, and return to Step 1 to edit other parameters. After adjustment, press "SETUP" button to return to the main menu, and all the settings are automatically saved.



Diagram 13

7. System Setting

Press "SETUP" to enter the setup menu, Press "▲" "▼" to select KIT SETUP, refer to Diagram 14. Press confirm button to enter kit setup menu.



Diagram 14

Step 1: Press "▲" "▼" to select desired parameter to edit including: TRIG SCAN, EQ BASS, EQ TREBLE, REV VOL(verb volume), REV TYPE(verb type), LOCAL(local sound), MIDI CH(MIDI channel). Then press confirm button to enter the parameter. The menu of all parameters are as below.



K1 KIT SETUP ◀
1. TRIG SCAN: 1

TRIG SCAN: 1~21



K1 KIT SETUP ◀
2. EQ BASS: +50

EQ BASS: -64~+63



K1 KIT SETUP ◀
3. EQ TREBLE: +50

EQ TREBLE: -64~+63



K1 KIT SETUP ◀
4. REV VOL: 32

REV VOL: 0~127



K1 KIT SETUP ◀
5. REV TYPE: 1

REV TYPE: 0~4



K1 KIT SETUP ◀
6. LOCAL: NO

LOCAL: ON/OFF



K1 KIT SETUP ◀
7. MIDI CH: 10

MIDI CH: 1~16

Step 2: Press “▲” “▼” to adjust the parameter, refers to Diagram 15. Press confirm button to confirm, and return to Step 1 to edit other parameters. After adjustment, press "SETUP" button to return to the main menu, and all the settings are automatically saved.



K1 KIT SETUP
1. TRIG SCAN: 1 ◀

Diagram 15

8. Restore Kit Setting

Press "SETUP" to enter the setup menu, then press “▲” “▼” to select KIT RESET. Press confirm button to restore factory settings of the current drum kit. The indicator turns on Red color and then Off, which indicating setting restored. Refers to Diagram 16.

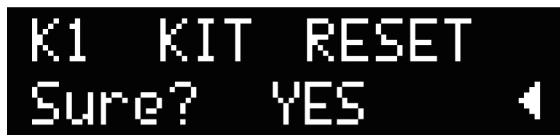

K1 KIT RESET
Sure? YES ◀

Diagram 16

9. Auto Power Off

Press "SETUP" to enter the setup menu, then press “▲” “▼” to select AUTO OFF. Press confirm button to enter automatic shutdown menu. Press turn switch knob to select standby time length, press confirm button to save the setting and return to the main menu. Refer to Diagram 17.



Diagram 17

10. Factory Reset

Press "SETUP" to enter the setup menu, then press "▲" "▼" to select FACTORY RESET. Press confirm button to restore factory settings of all the drum kits. The indicators turns Red color and then Off, which indicating setting restored. Refer to Diagram 18.



Diagram 18

11. Anti-crosstalk Function

When crosstalk occurs, adjusting the corresponding value with this function can effectively solve the crosstalk problem. Press "SETUP" button to enter the settings menu, press "▲" "▼" to select XTALK SETUP, refer to diagram 19.



Diagram 19

Press confirm button to enter XTALK setting, for example.

When the snare drum is struck, the sound of the cymbal appears:

1. Automatic recognition of drums or cymbals when struck (strike snare drum "SD") refer to diagram 20.



Diagram 20

2. Press the confirm button to switch to the crosstalk drum pad, and press the "METRO." button to select the drum pad or cymbal corresponding to the sound that crosstalk appears (select cymbal "CR1") refer to diagram 21.



Diagram 21

3. Press "▲" "▼" to adjust the parameter. Increase the corresponding value, press the SETUP button to return and automatically save the parameters after finishing the adjustment.

Note: The larger the value, the more serious the impact. It is best to adjust to no crosstalk, try not to make the value too large.

Menu list

Sens	Sensitivity adjustment. The value corresponds to the minimum signal triggered by the pad or cymbal you strike. The smaller the value, the higher the sensitivity.
Velo	The force curve, which can be modified to your proper strike force and your habit. 0: LINER, 1: EXP1, 2: EXP2, 3: EXP3, 4: LOG1, 5: LOG2, 6: LOUD1, 7: LOUD2
Rev	Pad or cymbal reverb effect level. The bigger the value, the greater the reverb level.
Pan	Sound image, to adjust sound positions.
Level	Pad or cymbal volume level
Voice	Pad or cymbal sound, to select a different sound for a certain pad or cymbal.
Note	Midi mapping value. Default setting to general Midi mapping (Japan MIDI Standards Committee)
Mask	To prevent double triggers. When playing the bass drum, the hammer will rebound and hit the drum again (make a 2nd sound). Setting a certain value of mask time will prevent this situation happening. If the value is big, it is hard to play fast. Adjust the value as small as possible.
Pitch	With higher value, the pitch of drum pad/cymbal will be higher.
Trig Scan	The monitoring time length between each two trigger signal. The bigger the value is, the longer the time. Set it as small as possible.
Midi Ch	MIDI signal channel, defaulted channel 10.
Local	Local is On by default. Sound will be outputed along with MIDI signal when On. Only MIDI signal without sound when Off.
Rev Type	Reverb effect type 0: room1, 1: room2, 2: hall, 3: studio, 4: stage
Rev Vol	Reverb effect volume level
EQ Treble	Volume level of high frequency
EQ Bass	Volume level of low frequency
Kit Reset	Reset current drum kit sound to defaulted factory setup
Auto Off	Automatic shutdown time length when the machine at standby mode. Options of 30 minutes or 1 hour.
Factory Reset	Reset all changes to defaulted factory setup.
X-talk	Crosstalk parameter adjustment, adjust the corresponding crosstalk parameter to effectively solve the crosstalk occurrence

Metronome Function

Press button "METRO." to enter the metronome, the indicator turns red and flashes. Press "▲" "▼" to adjust tempo, refer to Diagram 22, Tempo range: 40-240BPM. Another press "METRO" to suspend metronome.



Diagram 22

Press "SETUP" button to select rhythm, press "▲" "▼" to adjust rhythm, refer to Diagram 23. Rhythm options: 1/4, 1/8, 1/8 A, Trip, Trip A, 1/16, 1/16 A, 1/16 B, 1/16 C, 1/16 D, 1/16 E, 6 Tup 1.



Diagram 23

Press "SETUP" button to select beat, press "▲" "▼" to adjust beat, refer to Diagram 24. Beat options: 1 ~ 8.



Diagram 24

Press "SETUP" button to select sound, press "▲" "▼" to adjust sound, refer to Diagram 25. sound options: 1 ~ 10.

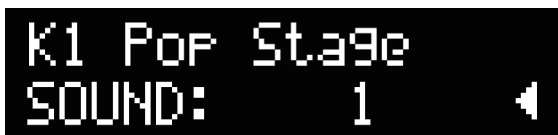

Diagram 25

Press "SETUP" button to select volume, press "▲" "▼" to adjust volume, refer to Diagram 26. volume options: 1 ~ 100.



Diagram 26

Pedals Adjustment

The pedals sensors' sensitivity might be affected by circumstances, temperature, etc.. If this happened, please adjust the pedals as below.



Diagram 27

1. Press Confirm Button and hold firstly, and then in the same time press "POWER" Button.
Till that module is ON and the screen shows as Diagram 26, release both buttons.
2. Stomp down and hold hi-hat pedal HHP till screen returns to the initial setup surface , which means HHP automatic setup finished, and then release HHP pedal.
3. Pedals automatic setup now finished. Enjoy your play.

Double Bass Mode

The E-Flex module has an option for double bass playing. To access this mode, press and hold both arrow buttons until the screen shows "DOUBLE BD PEDAL". The Hi-Hat pedal now functions as a second bass drum. The Hi-Hat sound will be open on all preset drum kits when double bass mode is engaged.

Bluetooth

Press and hold bluetooth button on the module till that the blue indicator is On. Search, on your phone, the ID 'ddrum EFLEX BT' and click to connect. A beep sound "Di..." will be gendered when bluetooth connection succeed.

Remind:

1. The bluetooth volume level is preset according to Android system. Please turn the volume down accordingly if you use a IOS system phone.
2. If you need to change the bluetooth connection of the amp to another phone, please disconnect the previous connection.

USB MIDI

Connect to your synthesizer or personal computer to play your MIDI music. MIDI (musical instrument digital interface) format list.

MIDI:

Function		Transmitted	Recognized	Remarks
Basic Channel	Default	10	1 ~ 8 & 10 ~ 16	
	Changed	x	x	
Mode	Default	x	Mode 3	
	Messages	x	x	
	Altered	*****	*****	
Note Number		0 ~ 127	0 ~ 127	
	True voice	*****	0 ~ 127	
Velocity	Note ON	0 ~ 127	0 ~ 127	
	Note OFF	x	0 ~ 127	
After Touch	Keyss	x	x	
	Channelss	x	x	
Pitch Bend		x	0	
Control Change	0	x	0	Bank Select
	1	x	0	Modulation
	4	x	0	Foot Control
	5	x	0	Portamento Time
	6	x	0	Data Entry
	7	x	0	Volume
	10	x	0	Pan
	11	x	0	Expression
	64	x	0	Sustain Pedal
	65	x	0	Portamento On/Off
	66	x	0	Sostenuto Pedal
	67	x	0	Soft Pedal
	71	x	0	Resonance
	72	x	0	Release Time
	73	x	0	Attack Time
	74	x	0	Cut Off
	80	x	0	Reverb Program
81	x	0	Chorus Program	
90	x	0	Reverb Level	
91	x	0	Chorus Level	
120	x	0	All Sound OFF	
121	x	0	Reset All Controller *1	
123	x	0	All Notes OFF *1	
Program Change		x	0	
System Exclusive		x	0	
System common	Song Position	x	x	
	Song Select	x	x	
	Tune	x	x	
System Real Time	Clock	x	x	
	Commands	x	x	
Aux Messages	Local ON/OFF	x	x	
	All Notes OFF	x	x	
	Active Sense	0	x	
	Reset	x	x	

Mode 1 : Omni On, Poly Mode 2 : Omni On, Mono 0 : Yes X : No
 Mode 3 : Omni Off, Poly Mode 4 : Omni Off, Mono Notes *1 Except 9, 10 Channel

Reminder: Product information is subject to change without prior notice.

Specifications

Drum Kit Contents	Crash cymbal, hi-hat, ride cymbal, tom drum * 3, sanre drum, hi-hat pedal , mechanical drum pedal and pad	
Drum Sound Kit Quantity	20	
Coach Music Files Preset	30	
Metronome	Tempo	40~240BPM
	Sound	1~10
	Rhythm	1/4,1/8,1/8A,Trip,TripA,1/16,1/16A,1/16B,1/16C,1/16D,1/16E,6Tupl
	Beat	1~8
Control Buttons	Power Button	
	Confirm button/ Volume Knob	
	SETUP Button	
	▲▼ Button	
	METRO. Button	
Bluetooth Button		
LCD Screen	32 characters by dot matrix	
Interface	6.35mm gauge audio port	
	3.5mm earphone port	
	CRASH2 port	
	3.5mm aux port	
	USB B type MIDI port	
	DB25 drums signal cables	
	AC/DC adapter port	
Power Voltage	DC9V ⊕ — ⊖	
Power Current	300mA	
Dimensions	83x26x68cm	
Accessories	Electronic drum kit, Assembly Direction, Operation Manual, Power Adapter, Drum Sticks, 6.35mm Audio Cable	

Troubleshooting

Faults	Check List	Solution
No sound / insufficient volume	Is the drum set well connected to your headphone or amp?	Check the connections
	Is the volume adjusted properly?	Check the volume knob
	Is the connection of audio cable correct?	Please check the connection
	Is the audio cable broken?	Try another piece of audio cable
	Is only one pad or cymbal no sound?	Please contact customer service
	Is the volume of some one pad or cymbal too low or high?	Follow Kit Edit steps to adjust the level
Hi-hat pedal or bass drum pedal responses badly	Is the connection correct?	Check the connection
	Is the pedal occasionally silent?	Follow Pedals Adjustment steps to adjust pedals sensitivity
	Are the pedals lack of or over sensitive?	Follow Kit Edit to adjust the pedals sensitivity
Cross talk	Is the drum kit assembled properly?	Check all the joints and fasten the screws
	Are DB25 audio cables loose?	Check all the connections of DB25 audio cable heads
	Is MIDI signal disordered?	Use TDX-APP or X-Talk and SENS edit to calibrate
USB connection to computer failed		Please restart the drum host machine and try again
Not to Power ON	Is the power turned On?	Use qualified AC/DC power adapter
	Does the power button function well?	Please contact customer service
Screen display abnormal	Is the screen dark or texts incoherent?	Please contact customer service
If you find any other faults not listed here, please contact your customer service.		

FCC Warning:

This equipment has been tested and found to comply with the limits for a Class B digital device, pursuant to part 15 of the FCC Rules. These limits are designed to provide reasonable protection against harmful interference in a residential installation. This equipment generates, uses and can radiate radio frequency energy and, if not installed and used in accordance with the instructions, may cause harmful interference to radio communications. However, there is no guarantee that interference will not occur in a particular installation. If this equipment does cause harmful interference to radio or television reception, which can be determined by turning the equipment off and on, the user is encouraged to try to correct the interference by one or more of the following measures:

- Reorient or relocate the receiving antenna.
- Increase the separation between the equipment and receiver.
- Connect the equipment into an outlet on a circuit different from that to which there caiver is connected.
- Consult the dealer or an experienced radio/TV technician for help.

Caution: Any changes or modifications to this device not explicitly approved by manufacturer could void your authority to operate this equipment.

This device complies with part 15 of the FCC Rules. Operation is subject to the following two conditions: (1) This device may not cause harmful interference, and (2) this device must accept any interference received, including interference that may cause undesired operation.

This equipment complies with FCC radiation exposure limits set forth for an uncontrolled environment. This equipment should be installed and operated with minimum distance 20cm between the radiator & your body.



MADE IN CHINA

